

## 5 CIRCUIT RECONCILIATION LABYRINTH

Geoffrey J Rodda 6 Boathaven Grove San Remo. Victoria.  
Mobile: 0408 138 065 Email: [gjrodda@gmail.com](mailto:gjrodda@gmail.com)

Copyright: Clare Wilson 2002. All Rights Reserved

Note: As we already have permission to use the Reconciliation Design there is no need to get permission. However, Copyright is to be noted when creating the design, on documents, notifying Clare, sending photographs of any installation.

---

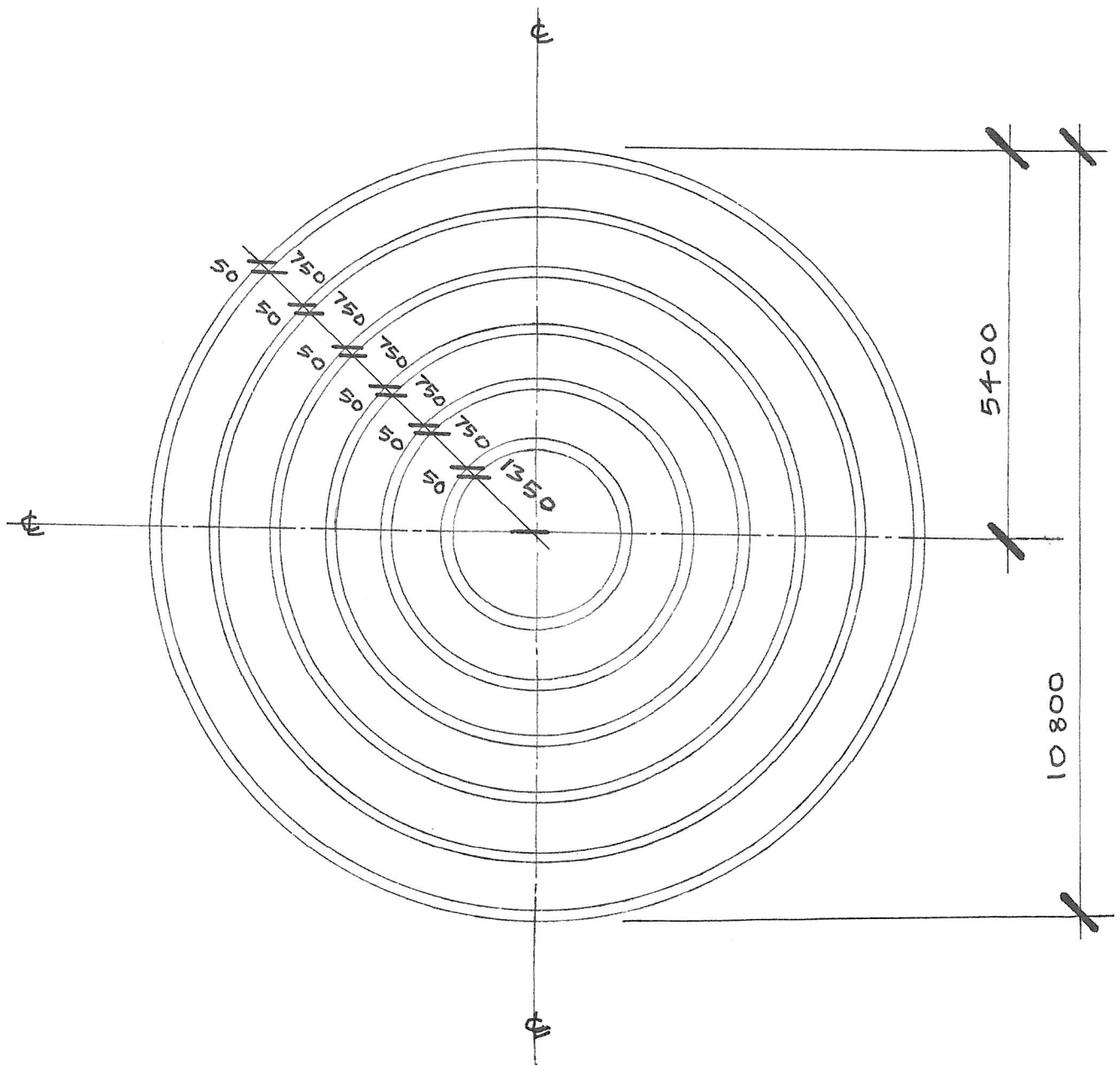

## Step 1:

Using the Labyrinth Set-out device ( page 5 ) draw the concentric circles onto canvas or other material surface, using the dimensions shown.

Use a soft grade lead pencil.

Note:

The centre block will need to be weighed down, during this process, using circular steel weights, to prevent movement.

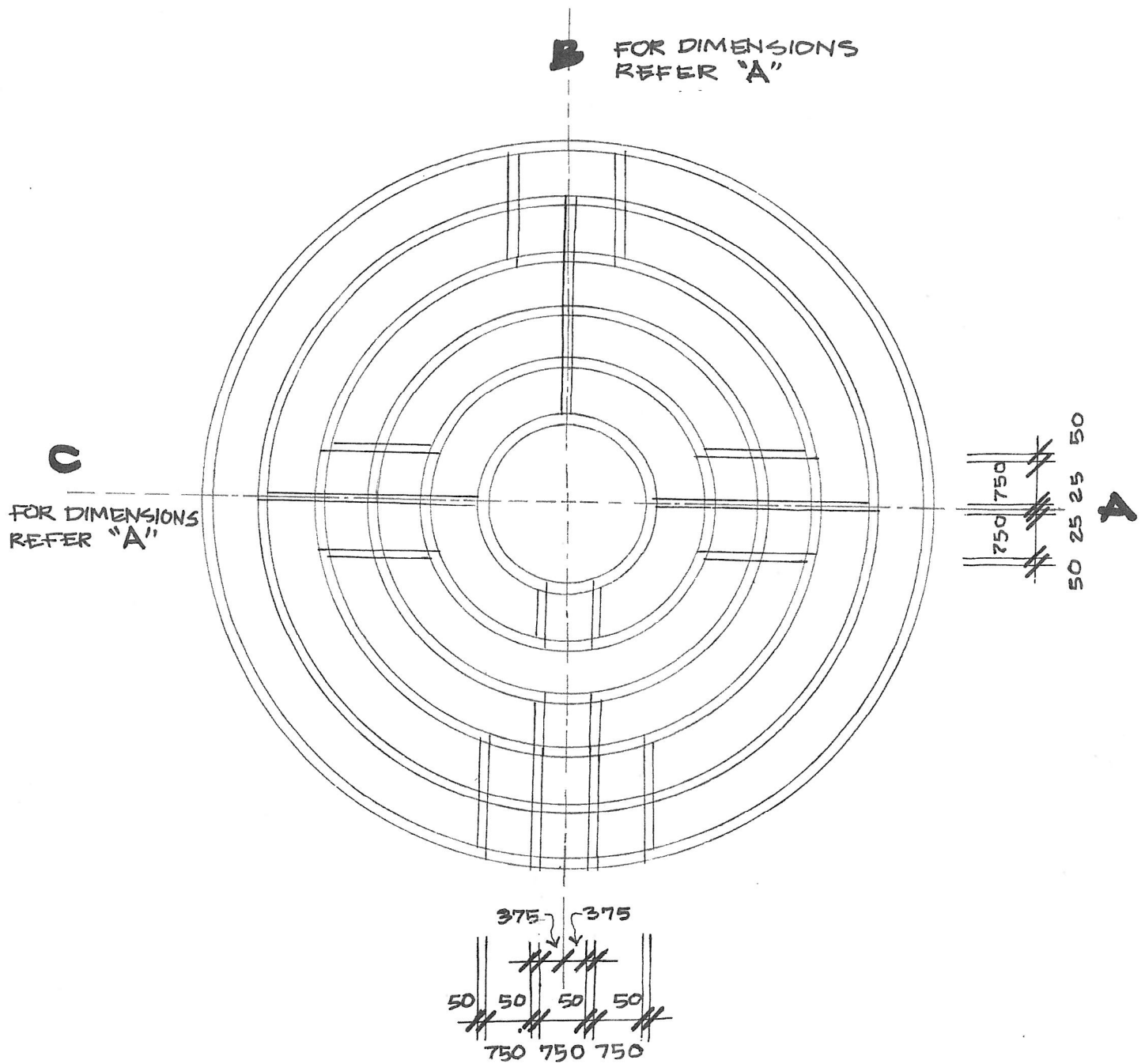

## Step 2:

1. Locate the 4 compass points. ( shown dotted )
  2. Using a straight edge, draw in the straight lines ( 50mm wide ) at the major straight turning points and at the Entry / Entry points, to the dimensions shown.
- Use a soft grade lead pencil.



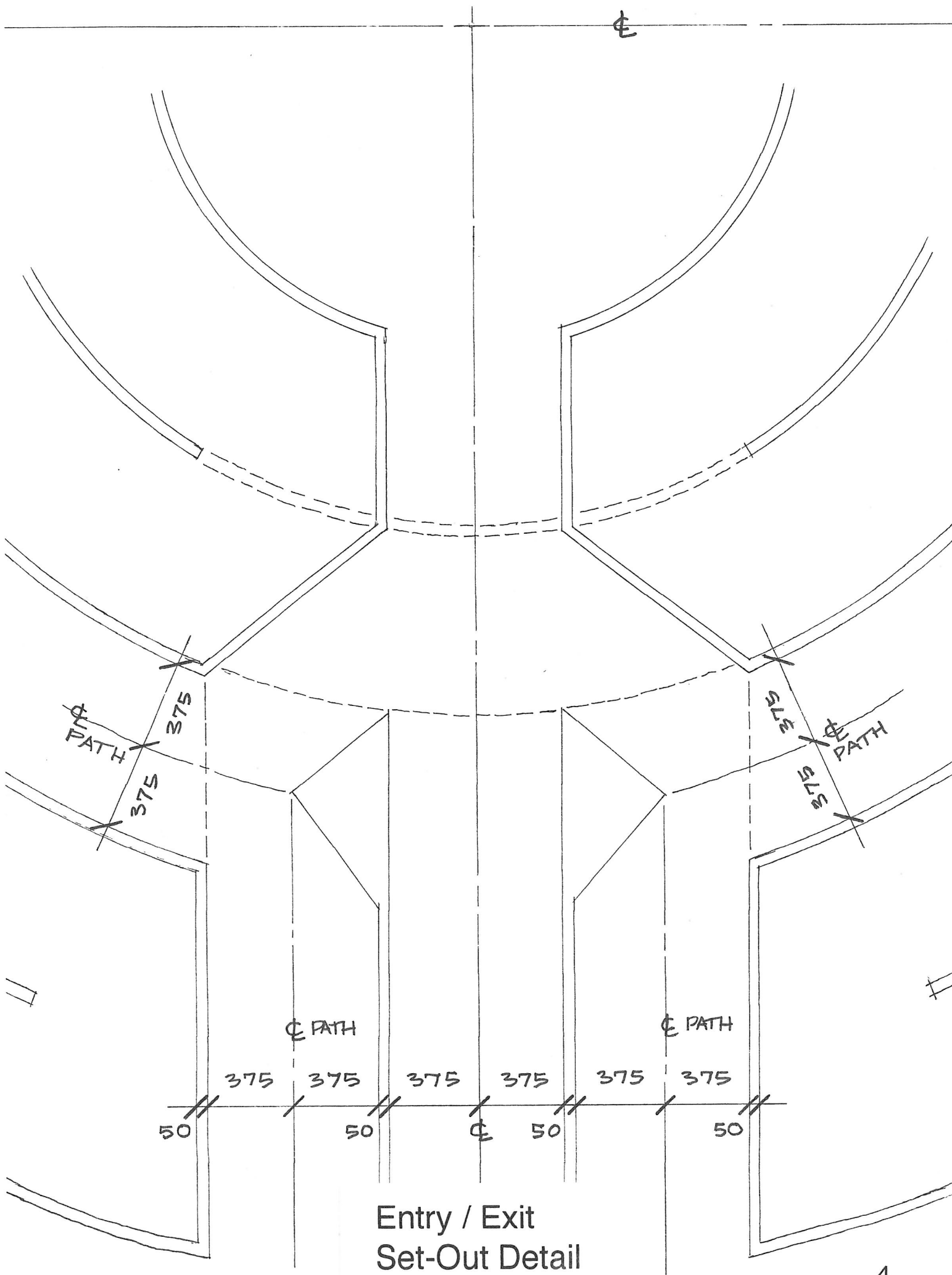

Entry / Exit  
Set-Out Detail

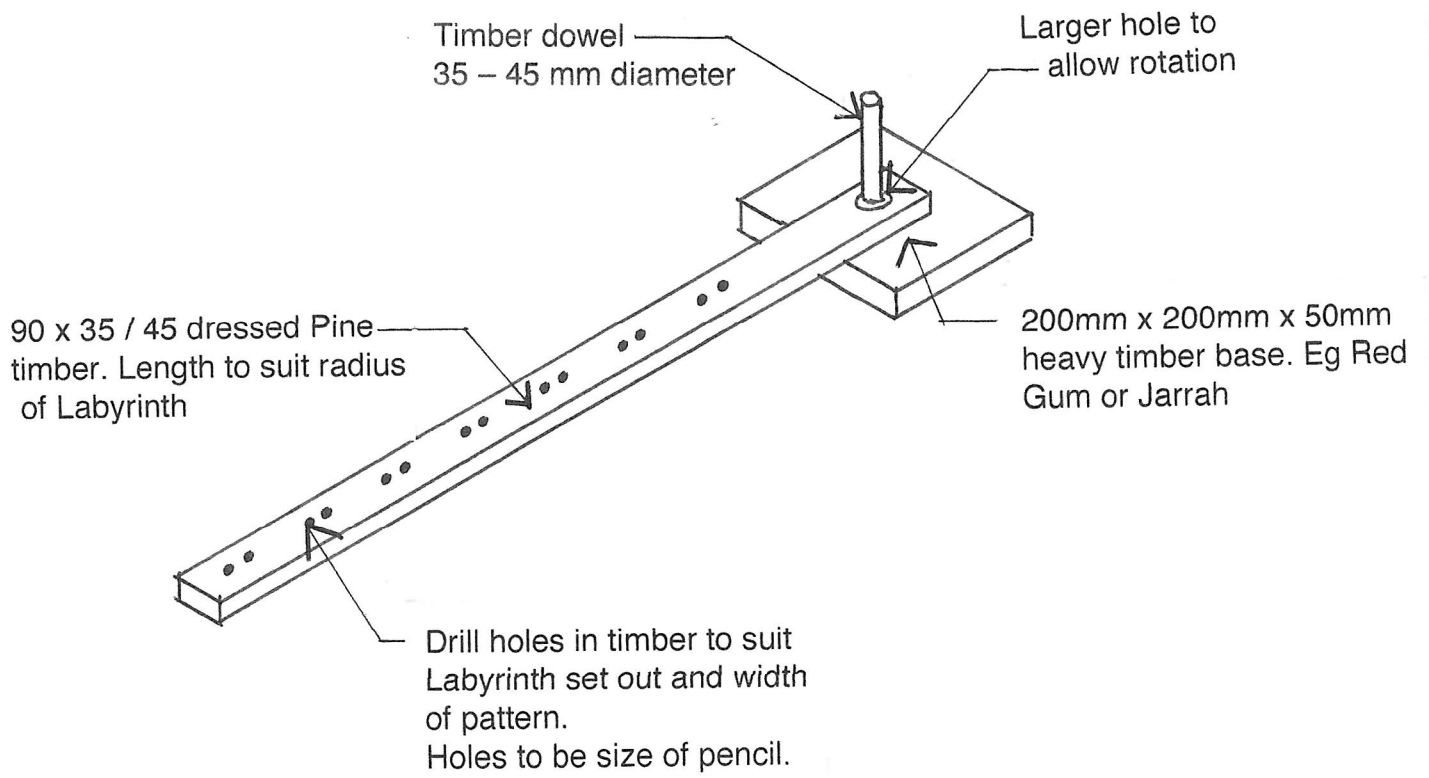

---

## Labyrinth Set-Out Device

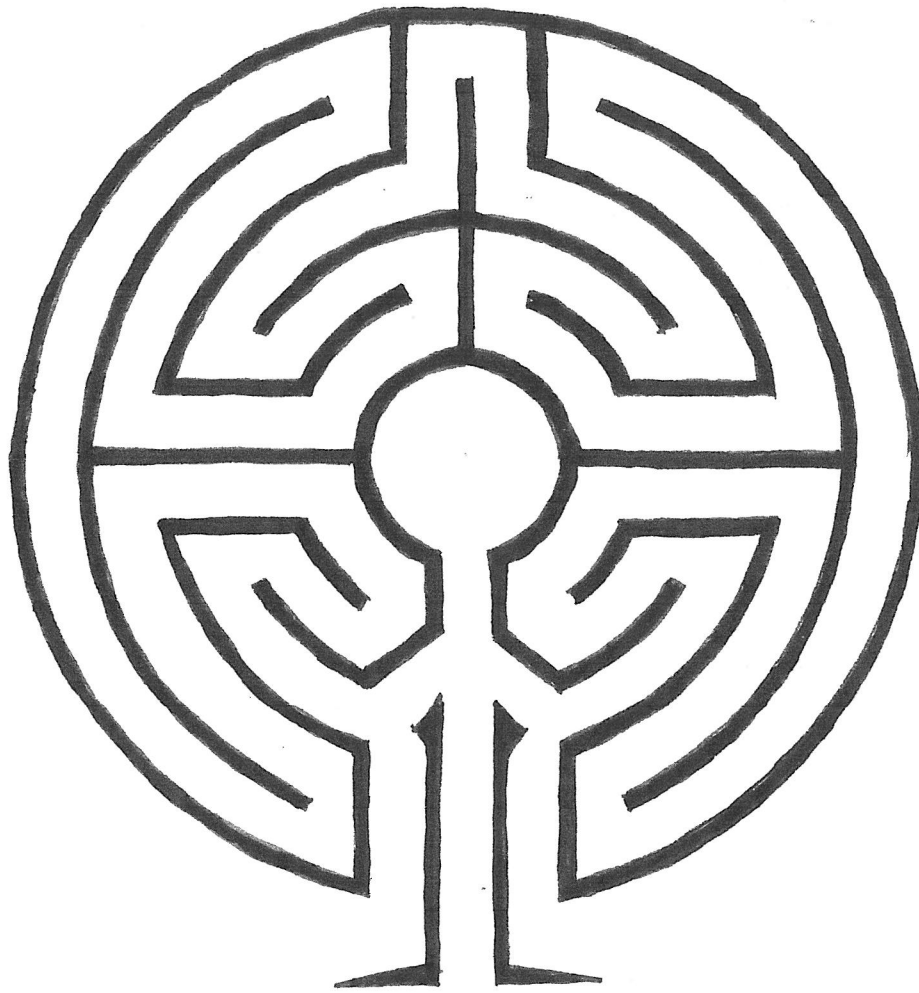

---

#### Step 4:

Using masking tape, or similar, mask out each side of the 50mm lines. Then paint the labyrinth pattern, using a selected paint colour..

## Dimensions and Calculations

Path width – 750mm

Pattern width – 50mm

Centre – 1350mm

Overall diameter – 10.80 metres

Note: It is possible to vary the path width, however, the overall diameter of the centre must remain one quarter of the overall diameter of the Labyrinth.